

PART OF SECTIONS 17 & 18, TOWNSHIP 18 NORTH, RANGE 18 EAST, W.M.

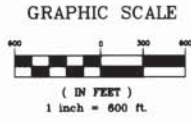

- LEGEND**
- SET 5/8" REBAR W/ YELLOW CAP - "CRUSE 18078"
  - FOUND PIN & CAP
  - x — FENCE
  - ( ) RECORD INFORMATION

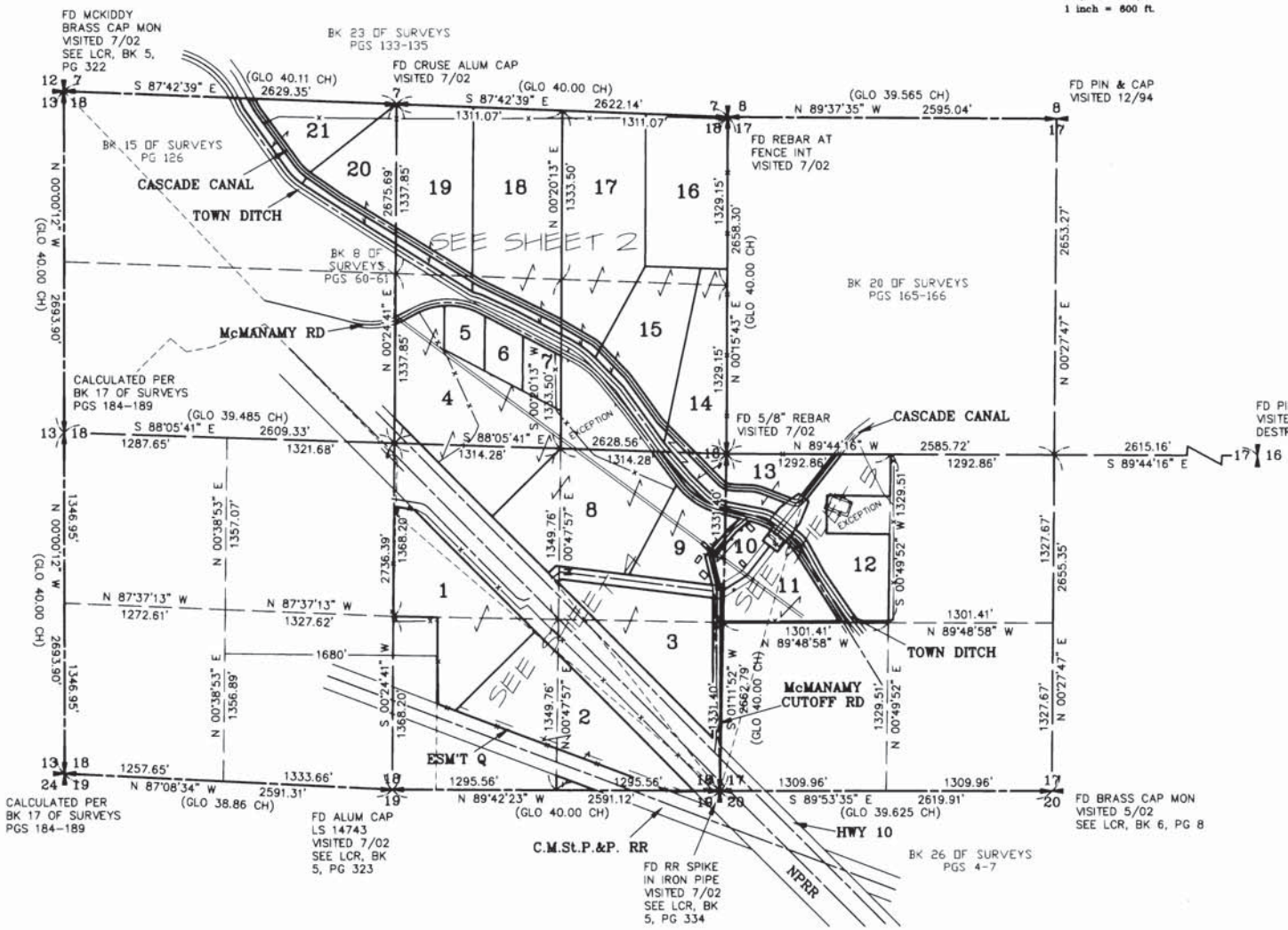

**AUDITOR'S CERTIFICATE**

Filed for record this 22ND day of NOVEMBER, 2002, at 12:07 PM, in Book 28 of Surveys at page(s) 103 at the request of Cruse & Associates.

DAVID B. BOWEN  
 HITITAS COUNTY AUDITOR

**SURVEYOR'S CERTIFICATE**

This map correctly represents a survey made by me or under my direction in conformance with the requirements of the Survey Recording Act at the request of MARY MCMANAMY in JULY of 2002.

*Charles A. Cruse, Jr.*  
 CHARLES A. CRUSE, JR.  
 Professional Land Surveyor  
 License No. 18078

NOVEMBER 22, 2002  
 DATE

**CRUSE & ASSOCIATES**  
 PROFESSIONAL LAND SURVEYORS  
 217 East Fourth Street P.O. Box 959  
 Ellensburg, WA 98926 (509) 962-8242

**McMANAMY PROPERTY**

X	X	X		
X	X	X		
X	X	X		
X	X	X		

PART OF SECTIONS 17 & 18, TOWNSHIP 18 NORTH, RANGE 18 EAST, W.M.

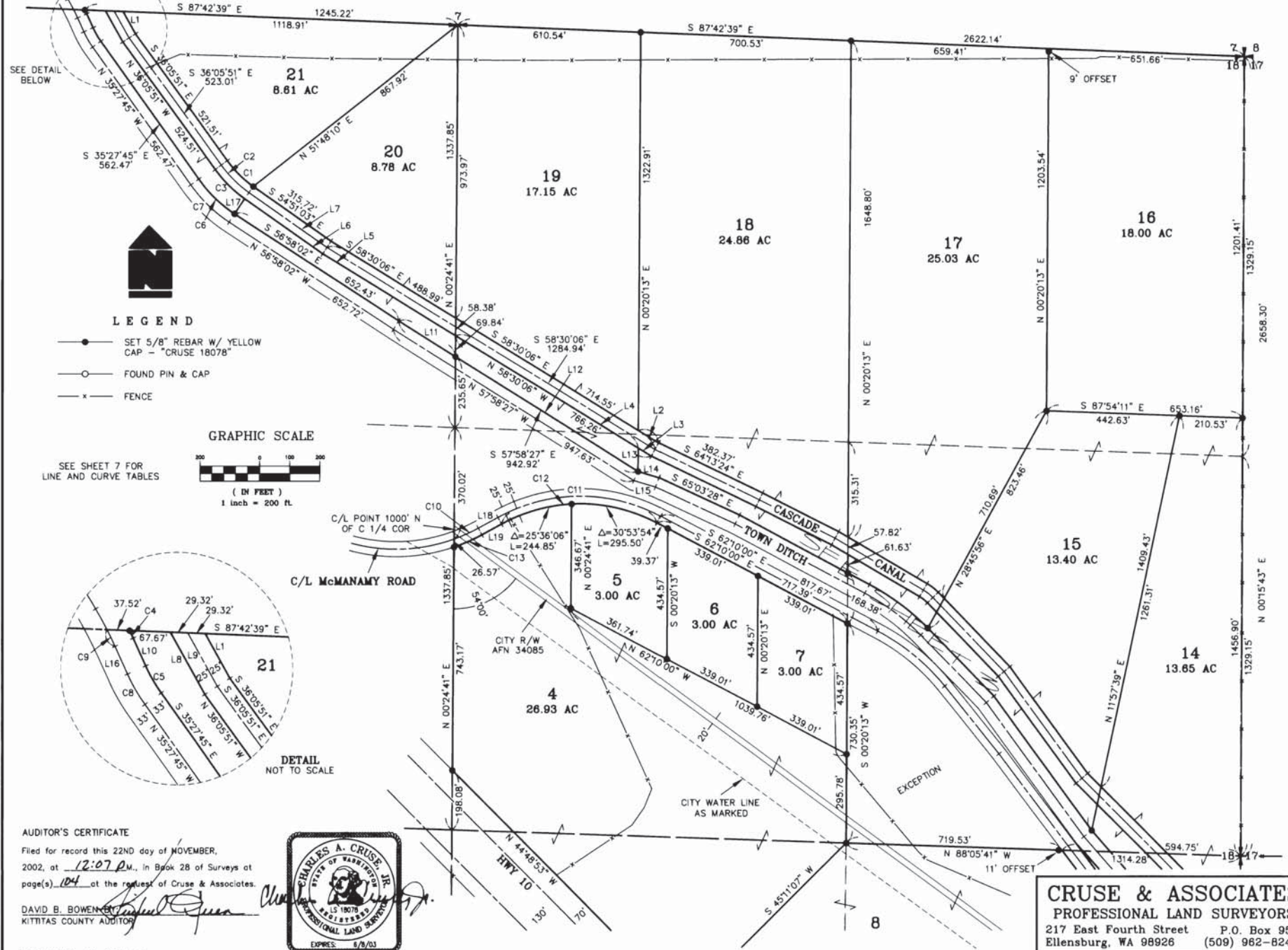

LEGEND

- SET 5/8" REBAR W/ YELLOW CAP - "CRUISE 18078"
- FOUND PIN & CAP
- x — FENCE

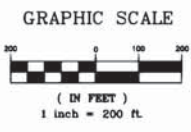

SEE SHEET 7 FOR LINE AND CURVE TABLES

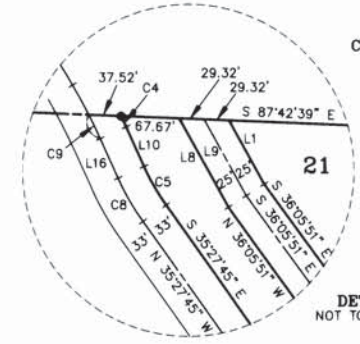

AUDITOR'S CERTIFICATE  
 Filed for record this 22ND day of NOVEMBER, 2002, at 12:07 P.M., in Book 28 of Surveys at page(s) 104 at the request of Cruse & Associates.

DAVID B. BOWEN  
 KITTITAS COUNTY AUDITOR

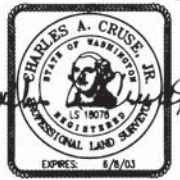

NOVEMBER 22, 2002

**CRUSE & ASSOCIATES**  
 PROFESSIONAL LAND SURVEYORS  
 217 East Fourth Street P.O. Box 959  
 Ellensburg, WA 98926 (509) 962-8242  
**McMANAMY PROPERTY**

# PART OF SECTIONS 17 & 18, TOWNSHIP 18 NORTH, RANGE 18 EAST, W.M.

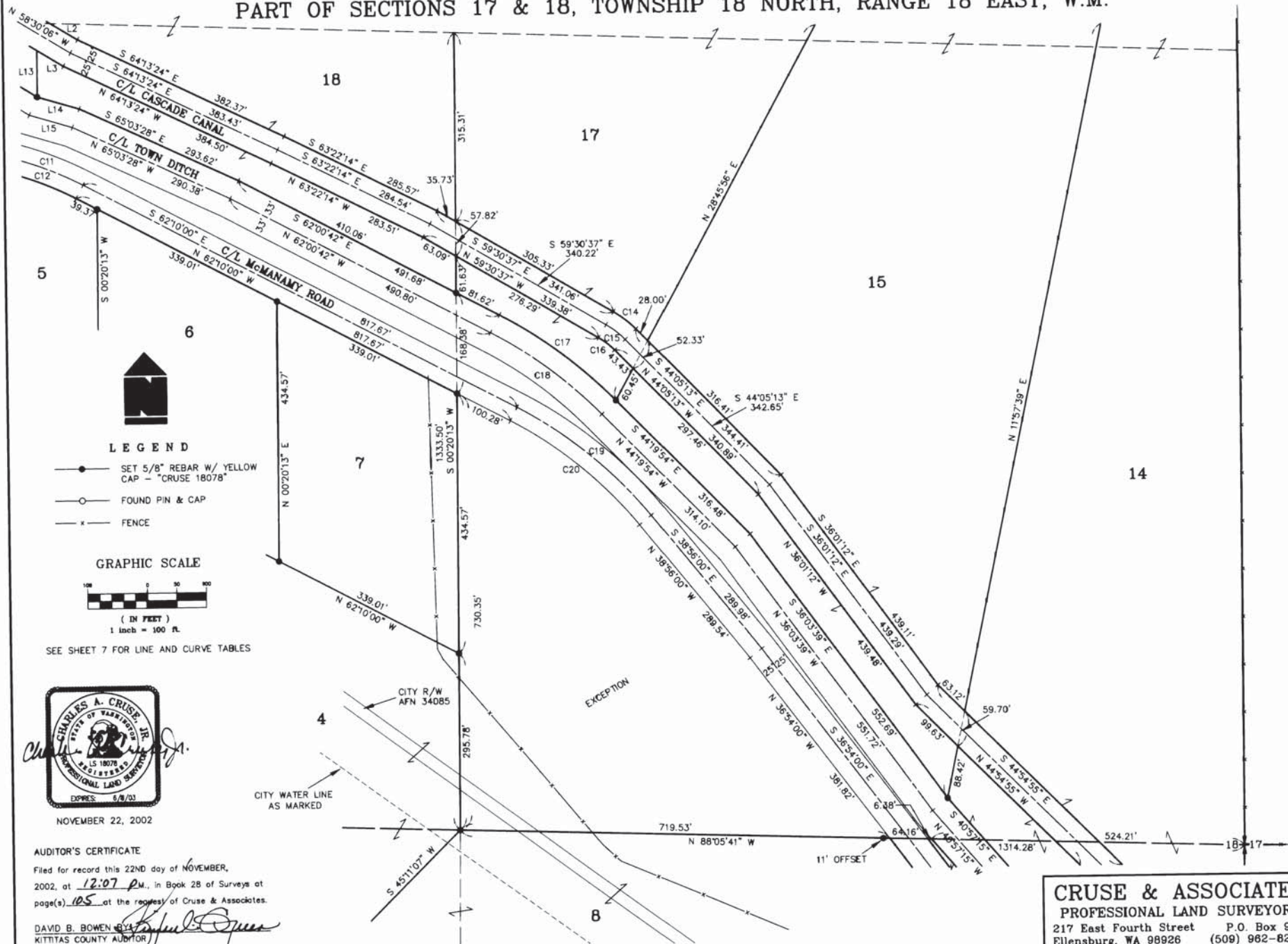

### LEGEND

- SET 5/8" REBAR W/ YELLOW CAP - "CRUSE 1807B"
- FOUND PIN & CAP
- x — FENCE

### GRAPHIC SCALE

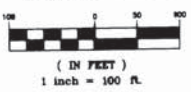

SEE SHEET 7 FOR LINE AND CURVE TABLES



NOVEMBER 22, 2002

### AUDITOR'S CERTIFICATE

Filed for record this 22ND day of NOVEMBER, 2002, at 12:07 P.M., in Book 28 of Surveys at page(s) 105 at the request of Cruse & Associates.

DAVID B. BOWEN, Auditor  
KITTITAS COUNTY AUDITOR

**CRUSE & ASSOCIATES**  
 PROFESSIONAL LAND SURVEYORS  
 217 East Fourth Street P.O. Box 959  
 Ellensburg, WA 98926 (509) 962-8242  
**McMANAMY PROPERTY**

PART OF SECTIONS 17 & 18, TOWNSHIP 18 NORTH, RANGE 18 EAST, W.M.



LEGEND

- SET 5/8" REBAR W/ YELLOW CAP - "CRUSE 18078"
- FOUND PIN & CAP
- x- FENCE

GRAPHIC SCALE



SEE SHEET 7 FOR LINE AND CURVE TABLES

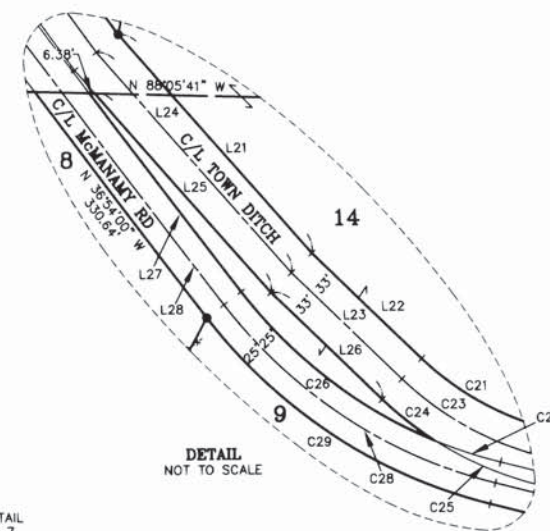

DETAIL NOT TO SCALE

AUDITOR'S CERTIFICATE

Filed for record this 22ND day of NOVEMBER, 2002, at 12:07 PM, in Book 28 of Surveys at page(s) 106 at the request of Cruse & Associates.

DAVID B. BOWEN *[Signature]*  
KITITAS COUNTY AUDITOR

**CRUSE & ASSOCIATES**  
PROFESSIONAL LAND SURVEYORS  
217 East Fourth Street P.O. Box 959  
Ellensburg, WA 98926 (509) 982-8242

McMANAMY PROPERTY

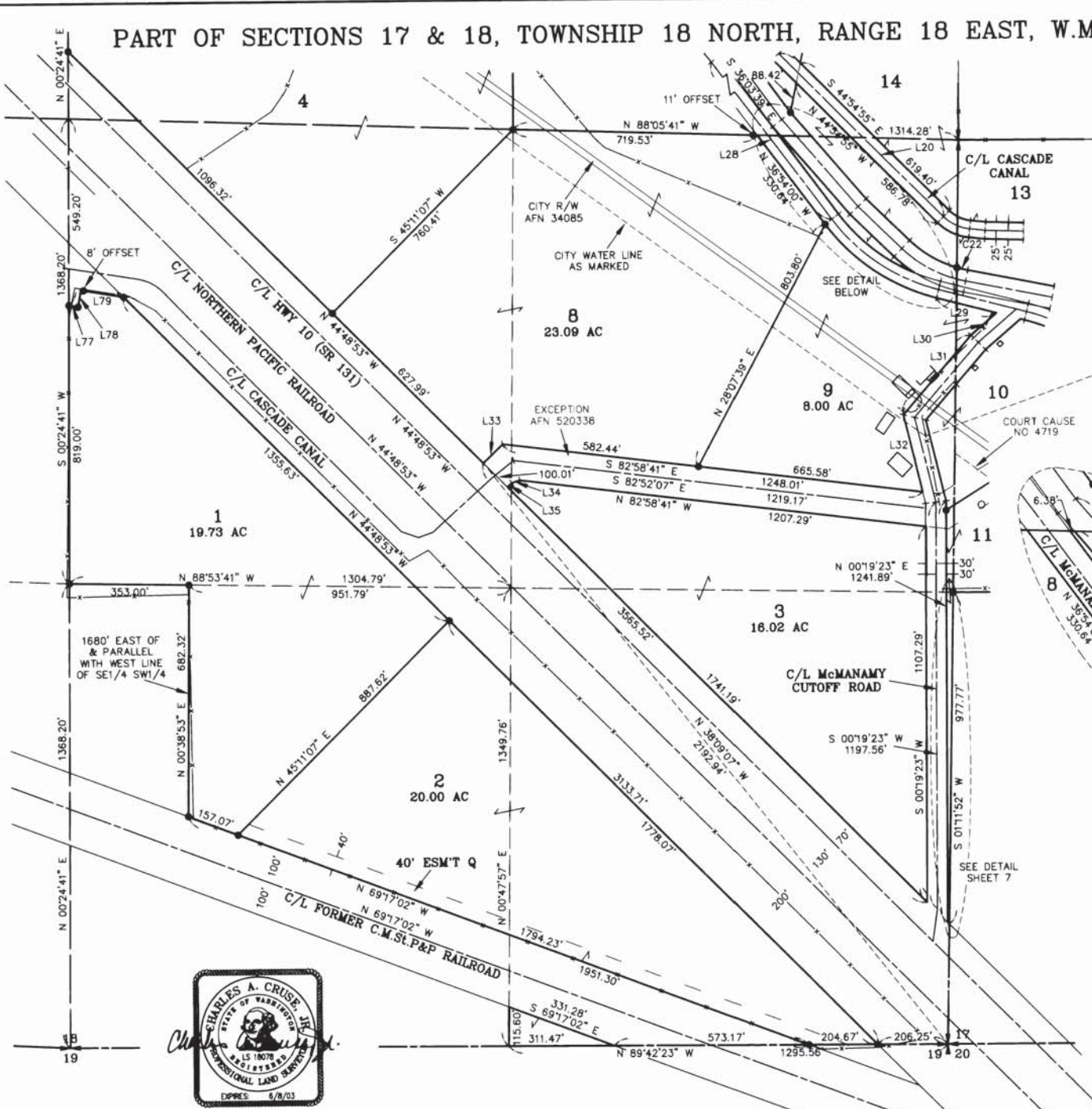

# PART OF SECTIONS 17 & 18, TOWNSHIP 18 NORTH, RANGE 18 EAST, W.M.



### LEGEND

- SET 5/8" REBAR W/ YELLOW CAP - "CRUSE 18078"
- FOUND PIN & CAP
- FENCE

### GRAPHIC SCALE

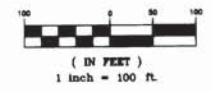

SEE SHEET 7 FOR LINE AND CURVE TABLES

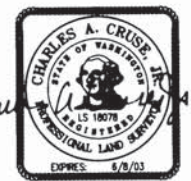

NOVEMBER 22, 2002

### AUDITOR'S CERTIFICATE

Filed for record this 22ND day of NOVEMBER, 2002, at 12:07 PM, in Book 28 of Surveys at page(s) 107 at the request of Cruse & Associates.

DAVID B. BOWEN, Auditor  
KITITIAS COUNTY AUDITOR

**CRUSE & ASSOCIATES**  
 PROFESSIONAL LAND SURVEYORS  
 217 East Fourth Street P.O. Box 959  
 Ellensburg, WA 98926 (509) 962-8242

**McMANAMY PROPERTY**

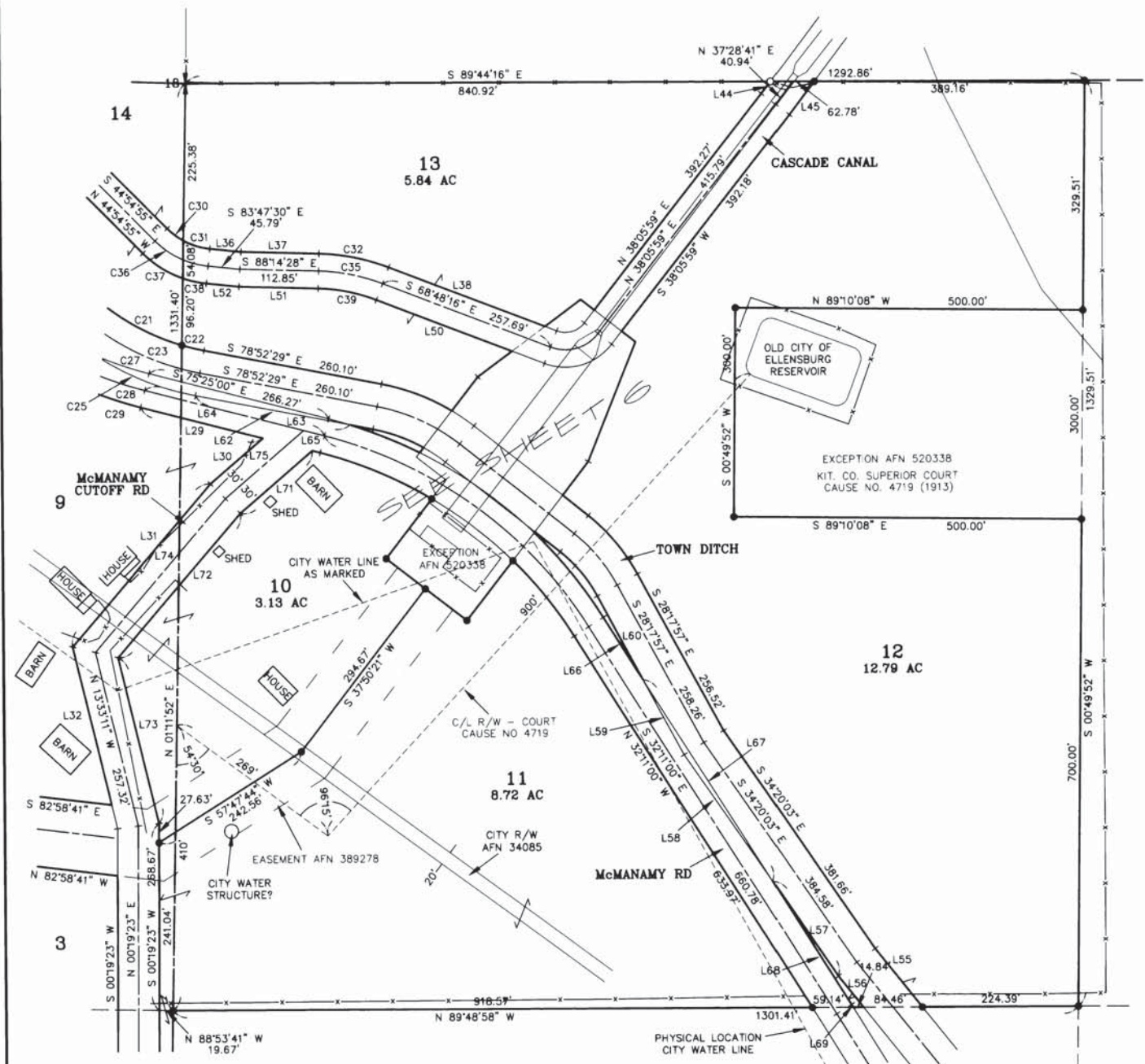

# PART OF SECTIONS 17 & 18, TOWNSHIP 18 NORTH, RANGE 18 EAST, W.M.



### LEGEND

- SET 5/8" REBAR W/ YELLOW CAP - "CRUSE 18078"
- FOUND PIN & CAP
- x- FENCE

### GRAPHIC SCALE

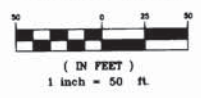

SEE SHEET 7 FOR LINE AND CURVE TABLES

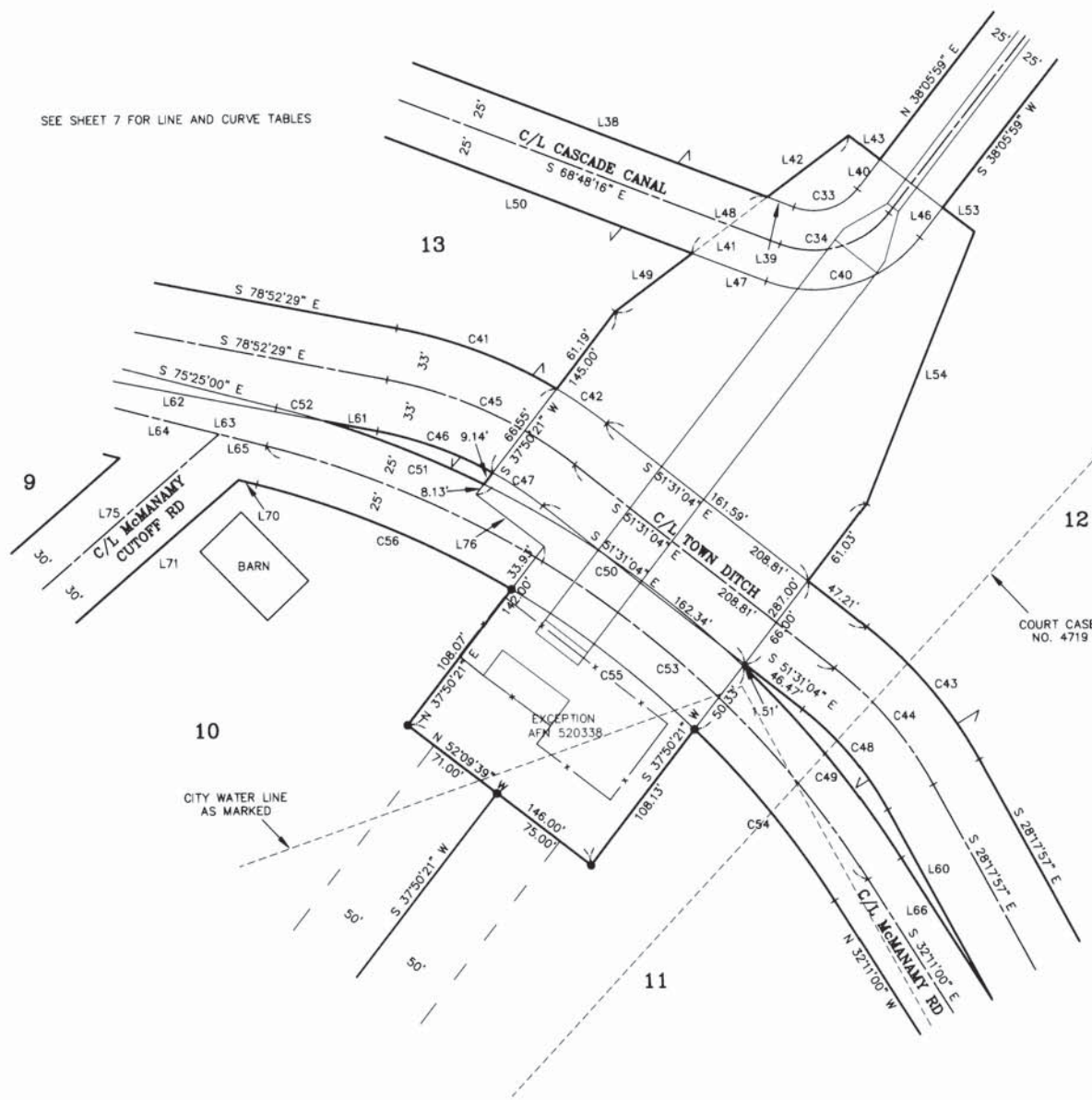

COURT CASE NO. 4719

EXCEPTION AFN 520338

CITY WATER LINE AS MARKED

### AUDITOR'S CERTIFICATE

Filed for record this 22ND day of NOVEMBER, 2002, at 12:07 PM, in Book 28 of Surveys at page(s) 108 at the request of Cruse & Associates.

DAVID B. BOWEN, Auditor  
KITTITAS COUNTY AUDITOR

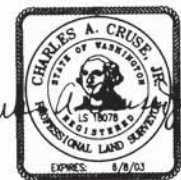

**CRUSE & ASSOCIATES**  
 PROFESSIONAL LAND SURVEYORS  
 217 East Fourth Street P.O. Box 959  
 Ellensburg, WA 98926 (509) 962-8242

**McMANAMY PROPERTY**

PART OF SECTIONS 17 & 18, TOWNSHIP 18 NORTH, RANGE 18 EAST, W.M.

LINE	DIRECTION	DISTANCE
L1	S 29°12'59" E	85.15'
L2	S 58°30'06" E	79.36'
L3	N 58°30'06" W	51.62'
L4	N 58°30'06" W	714.64'
L5	N 58°30'06" W	520.73'
L6	N 54°51'03" W	317.31'
L7	S 54°51'03" E	316.52'
L8	N 29°12'59" W	118.80'
L9	S 29°12'59" E	101.99'
L10	S 24°17'45" E	50.69'
L11	S 57°58'27" E	224.14'
L12	S 57°58'27" E	718.78'
L13	N 00°20'13" E	77.63'
L14	S 73°15'24" E	72.91'
L15	N 73°15'24" W	74.97'
L16	N 24°17'45" W	50.69'
L17	N 34°12'29" E	60.55'
L18	S 61°20'00" W	74.37'
L19	N 61°20'00" E	74.37'
L20	S 44°54'55" E	684.47'
L21	S 40°57'15" E	339.33'
L22	S 45°47'16" E	177.49'
L23	N 45°47'16" W	178.88'
L24	N 40°57'15" W	342.13'
L25	S 40°57'15" E	308.93'
L26	S 45°47'16" E	180.28'
L27	N 36°54'00" W	290.43'
L28	S 36°54'00" E	712.91'
L29	S 75°25'00" E	181.36'
L30	S 49°22'09" W	99.69'
L31	S 40°47'19" W	307.17'
L32	S 13°33'11" E	233.94'
L33	S 46°01'20" W	79.84'
L34	S 71°31'25" W	23.92'
L35	S 46°01'20" W	17.43'
L36	S 83°47'30" E	44.82'
L37	S 88°14'28" E	111.88'
L38	S 68°48'16" E	239.80'
L39	S 68°48'16" E	18.09'
L40	N 38°05'59" E	23.45'
L41	N 53°31'42" E	184.89'
L42	N 53°31'42" E	64.41'
L43	S 52°09'33" E	25.00'
L44	N 37°28'41" E	21.75'
L45	S 37°28'41" W	60.13'
L46	S 38°05'59" W	23.68'
L47	N 68°48'16" W	49.74'
L48	N 53°31'42" E	59.17'
L49	S 53°31'42" W	61.31'
L50	N 68°48'16" W	207.95'
L51	N 88°14'28" W	113.82'
L52	N 83°47'30" W	46.76'
L53	S 52°09'33" E	25.00'
L54	S 22°08'54" W	184.89'
L55	S 38°25'35" E	108.02'
L56	N 38°25'35" W	57.67'
L57	N 34°20'03" W	165.60'
L58	N 34°20'03" W	221.90'
L59	N 28°17'57" W	122.93'
L60	N 28°17'57" W	137.06'
L61	N 78°52'29" W	34.07'
L62	N 78°52'29" W	226.03'
L63	S 75°25'00" E	266.27'
L64	S 75°25'00" E	235.25'
L65	S 75°25'00" E	31.02'
L66	S 32°11'00" E	106.37'
L67	S 32°11'00" E	344.39'
L68	S 32°11'00" E	210.14'
L69	S 31°38'00" E	4.73'
L70	N 75°25'00" W	11.86'
L71	S 49°22'09" W	136.86'
L72	S 40°47'19" W	271.87'
L73	S 13°33'11" E	245.57'
L74	N 40°47'19" E	289.52'
L75	N 49°22'09" E	148.72'
L76	N 52°09'39" W	54.00'
L77	S 80°25'51" E	27.61'
L78	N 09°34'08" E	50.00'
L79	S 80°25'51" E	126.66'

CURVE	RADIUS	LENGTH	DELTA
C1	375.00'	122.74'	18°45'13"
C2	400.00'	130.92'	18°45'13"
C3	425.00'	139.11'	18°45'13"
C4	713.00'	13.90'	01°07'00"
C5	267.00'	52.04'	11°10'00"
C6	447.00'	167.77'	21°30'17"
C7	480.00'	180.16'	21°30'17"
C8	300.00'	58.47'	11°10'00"
C9	680.00'	30.70'	02°35'13"
C10	572.84'	88.44'	08°50'43"
C11	572.96'	565.00'	56°30'00"
C12	547.96'	540.35'	56°30'00"
C13	597.84'	101.48'	09°43'33"
C14	175.00'	47.11'	15°25'25"
C15	150.00'	40.38'	15°25'25"
C16	125.00'	33.65'	15°25'25"
C17	788.00'	243.15'	17°40'48"
C18	755.00'	232.97'	17°40'48"
C19	716.21'	290.42'	23°14'00"
C20	691.21'	280.28'	23°14'00"
C21	337.00'	162.01'	27°32'39"
C22	337.00'	32.60'	05°32'34"
C23	370.00'	213.67'	33°05'13"
C24	403.00'	77.64'	11°02'19"
C25	403.00'	155.08'	22°02'53"
C26	547.96'	288.00'	30°06'48"
C27	547.96'	80.37'	08°24'12"
C28	572.96'	385.17'	38°31'00"
C29	597.96'	401.98'	38°31'00"
C30	102.00'	28.97'	16°16'31"
C31	102.00'	40.24'	22°36'04"
C32	305.00'	103.47'	19°26'12"
C33	35.00'	44.65'	73°05'45"
C34	60.00'	76.55'	73°05'45"
C35	280.00'	94.99'	19°26'12"
C36	127.00'	86.17'	38°52'36"
C37	152.00'	68.36'	25°45'59"
C38	152.00'	34.78'	13°06'37"
C39	255.00'	86.50'	19°26'12"
C40	85.00'	108.44'	73°05'45"
C41	308.00'	108.57'	20°11'48"
C42	308.00'	38.49'	07°09'37"
C43	273.00'	110.63'	23°13'07"
C44	240.00'	97.26'	23°13'07"
C45	275.00'	131.30'	27°21'25"
C46	242.00'	77.75'	18°24'29"
C47	242.00'	37.80'	08°56'56"
C48	207.00'	83.88'	23°13'07"
C49	661.62'	157.76'	13°39'42"
C50	661.62'	200.94'	17°24'06"
C51	661.62'	108.47'	09°23'36"
C52	661.62'	32.06'	02°46'36"
C53	636.62'	480.37'	43°14'00"
C54	611.62'	140.30'	13°08'35"
C55	611.62'	146.35'	13°42'35"
C56	611.62'	174.86'	16°22'50"

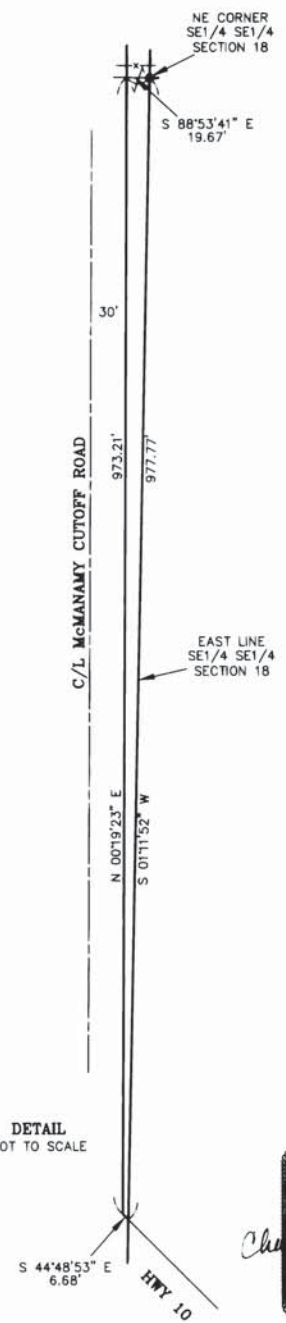

DETAIL NOT TO SCALE

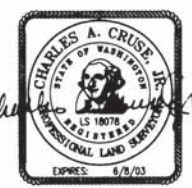

AUDITOR'S CERTIFICATE  
 Filed for record this 22ND day of NOVEMBER,  
 2002, at 12:07 P.M., in Book 28 of Surveys at  
 page(s) 109 at the request of Cruse & Associates.  
 DAVID B. BOWEN  
 KITTITAS COUNTY AUDITOR

**CRUSE & ASSOCIATES**  
 PROFESSIONAL LAND SURVEYORS  
 217 East Fourth Street P.O. Box 959  
 Ellensburg, WA 98926 (509) 962-8242  
**McMANAMY PROPERTY**

PART OF SECTIONS 17 & 18, TOWNSHIP 18 NORTH, RANGE 18 EAST, W.M.

NOTES:

1. THIS SURVEY WAS PERFORMED USING A NIKON DTM-521 TOTAL STATION. THE CONTROLLING MONUMENTS AND PROPERTY CORNERS SHOWN HEREON WERE LOCATED, STAKED AND CHECKED FROM A CLOSED FIELD TRAVERSE IN EXCESS OF 1:10,000 LINEAR CLOSURE AFTER AZIMUTH ADJUSTMENT.
2. THIS SURVEY MAY NOT SHOW ALL EASEMENTS OR IMPROVEMENTS WHICH MAY PERTAIN TO THIS PROPERTY.
3. THESE PARCELS ARE EXEMPT FROM THE KITTITAS COUNTY SUBDIVISION ORDINANCE UNDER CHAP. 16.04.020(1) AND (5) AND INTERVENING OWNERSHIP.
4. FOR SECTION CORNER DOCUMENTATION, SEE THE REFERENCED LCR'S AND RECORDS OF SURVEY.
5. THE 20 FOOT RIGHT OF WAY FOR THE CITY WATER LINE IS BASED ON THE LEGAL DESCRIPTION OF RECORD. THE EXISTING WATER LINE AS MARKED ON THE GROUND IS AMBIGUOUS EAST OF McMANAMY CUTOFF ROAD. ATTEMPTS TO COORDINATE WITH THE CITY OF ELLENSBURG WATER DEPARTMENT FOR MORE SPECIFIC INFORMATION WERE UNSUCCESSFUL. ACREAGES SHOWN INCLUDE THE WATER LINE RIGHT OF WAY.
6. BASIS OF BEARINGS IS RANDOMLY ASSIGNED AND MATCHES THE SURVEY RECORDED IN BOOK 23 OF SURVEYS, PAGES 133-135.

AUDITOR'S CERTIFICATE

Filed for record this 22ND day of NOVEMBER,  
 2002, at 12:07 p.m., in Book 28 of Surveys at  
 page(s) 110 at the request of Cruse & Associates.

DAVID B. BOWEN BY *David Bowen*  
 KITTITAS COUNTY AUDITOR

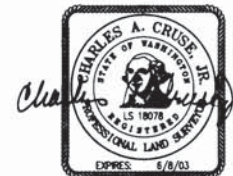

NOVEMBER 22, 2002

**CRUSE & ASSOCIATES**  
 PROFESSIONAL LAND SURVEYORS  
 217 East Fourth Street P.O. Box 959  
 Ellensburg, WA 98926 (509) 962-8242

**McMANAMY PROPERTY**



PART OF SECTIONS 17 & 18, TOWNSHIP 18 NORTH, RANGE 18 EAST, W.M.

LEGAL DESCRIPTIONS

ORIGINAL PARCELS - PART OF AFN 520338 AND 520339

PARCEL 1

PARCEL 1 OF THAT CERTAIN SURVEY AS RECORDED NOVEMBER 22, 2002 IN BOOK 28 OF SURVEYS AT PAGES 103-111 UNDER AUDITOR'S FILE NO. 200211220015, RECORDS OF KITTITAS COUNTY, WASHINGTON; BEING A PORTION OF THE SOUTHWEST QUARTER OF SECTION 18, TOWNSHIP 18 NORTH, RANGE 18 EAST, W.M., IN THE COUNTY OF KITTITAS, STATE OF WASHINGTON.

PARCEL 2

PARCEL 2 OF THAT CERTAIN SURVEY AS RECORDED NOVEMBER 22, 2002 IN BOOK 28 OF SURVEYS AT PAGES 103-111 UNDER AUDITOR'S FILE NO. 200211220015, RECORDS OF KITTITAS COUNTY, WASHINGTON; BEING A PORTION OF THE SOUTHWEST QUARTER OF SECTION 18, TOWNSHIP 18 NORTH, RANGE 18 EAST, W.M., IN THE COUNTY OF KITTITAS, STATE OF WASHINGTON.

PARCEL 3

PARCEL 3 OF THAT CERTAIN SURVEY AS RECORDED NOVEMBER 22, 2002 IN BOOK 28 OF SURVEYS AT PAGES 103-111 UNDER AUDITOR'S FILE NO. 200211220015, RECORDS OF KITTITAS COUNTY, WASHINGTON; BEING A PORTION OF THE SOUTHWEST QUARTER OF SECTION 18, TOWNSHIP 18 NORTH, RANGE 18 EAST, W.M., IN THE COUNTY OF KITTITAS, STATE OF WASHINGTON.

PARCEL 4

PARCEL 4 OF THAT CERTAIN SURVEY AS RECORDED NOVEMBER 22, 2002 IN BOOK 28 OF SURVEYS AT PAGES 103-111 UNDER AUDITOR'S FILE NO. 200211220015, RECORDS OF KITTITAS COUNTY, WASHINGTON; BEING A PORTION OF THE EAST HALF OF SECTION 18, TOWNSHIP 18 NORTH, RANGE 18 EAST, W.M., IN THE COUNTY OF KITTITAS, STATE OF WASHINGTON.

PARCEL 5

PARCEL 5 OF THAT CERTAIN SURVEY AS RECORDED NOVEMBER 22, 2002 IN BOOK 28 OF SURVEYS AT PAGES 103-111 UNDER AUDITOR'S FILE NO. 200211220015, RECORDS OF KITTITAS COUNTY, WASHINGTON; BEING A PORTION OF THE EAST HALF OF SECTION 18, TOWNSHIP 18 NORTH, RANGE 18 EAST, W.M., IN THE COUNTY OF KITTITAS, STATE OF WASHINGTON.

PARCEL 6

PARCEL 6 OF THAT CERTAIN SURVEY AS RECORDED NOVEMBER 22, 2002 IN BOOK 28 OF SURVEYS AT PAGES 103-111 UNDER AUDITOR'S FILE NO. 200211220015, RECORDS OF KITTITAS COUNTY, WASHINGTON; BEING A PORTION OF THE EAST HALF OF SECTION 18, TOWNSHIP 18 NORTH, RANGE 18 EAST, W.M., IN THE COUNTY OF KITTITAS, STATE OF WASHINGTON.

PARCEL 7

PARCEL 7 OF THAT CERTAIN SURVEY AS RECORDED NOVEMBER 22, 2002 IN BOOK 28 OF SURVEYS AT PAGES 103-111 UNDER AUDITOR'S FILE NO. 200211220015, RECORDS OF KITTITAS COUNTY, WASHINGTON; BEING A PORTION OF THE EAST HALF OF SECTION 18, TOWNSHIP 18 NORTH, RANGE 18 EAST, W.M., IN THE COUNTY OF KITTITAS, STATE OF WASHINGTON.

PARCEL 8

PARCEL 8 OF THAT CERTAIN SURVEY AS RECORDED NOVEMBER 22, 2002 IN BOOK 28 OF SURVEYS AT PAGES 103-111 UNDER AUDITOR'S FILE NO. 200211220015, RECORDS OF KITTITAS COUNTY, WASHINGTON; BEING A PORTION OF THE EAST HALF OF SECTION 18, TOWNSHIP 18 NORTH, RANGE 18 EAST, W.M., IN THE COUNTY OF KITTITAS, STATE OF WASHINGTON.

PARCEL 9

PARCEL 9 OF THAT CERTAIN SURVEY AS RECORDED NOVEMBER 22, 2002 IN BOOK 28 OF SURVEYS AT PAGES 103-111 UNDER AUDITOR'S FILE NO. 200211220015, RECORDS OF KITTITAS COUNTY, WASHINGTON; BEING A PORTION OF THE SOUTHWEST QUARTER OF SECTION 17, AND OF THE SOUTHWEST QUARTER OF SECTION 18, ALL IN TOWNSHIP 18 NORTH, RANGE 18 EAST, W.M., IN THE COUNTY OF KITTITAS, STATE OF WASHINGTON.

PARCEL 10

PARCEL 10 OF THAT CERTAIN SURVEY AS RECORDED NOVEMBER 22, 2002 IN BOOK 28 OF SURVEYS AT PAGES 103-111 UNDER AUDITOR'S FILE NO. 200211220015, RECORDS OF KITTITAS COUNTY, WASHINGTON; BEING A PORTION OF THE SOUTHWEST QUARTER OF SECTION 17, AND OF THE SOUTHWEST QUARTER OF SECTION 18, ALL IN TOWNSHIP 18 NORTH, RANGE 18 EAST, W.M., IN THE COUNTY OF KITTITAS, STATE OF WASHINGTON.

PARCEL 11

PARCEL 11 OF THAT CERTAIN SURVEY AS RECORDED NOVEMBER 22, 2002 IN BOOK 28 OF SURVEYS AT PAGES 103-111 UNDER AUDITOR'S FILE NO. 200211220015, RECORDS OF KITTITAS COUNTY, WASHINGTON; BEING A PORTION OF THE SOUTHWEST QUARTER OF SECTION 17, AND OF THE SOUTHWEST QUARTER OF SECTION 18, ALL IN TOWNSHIP 18 NORTH, RANGE 18 EAST, W.M., IN THE COUNTY OF KITTITAS, STATE OF WASHINGTON.

PARCEL 12

PARCEL 12 OF THAT CERTAIN SURVEY AS RECORDED NOVEMBER 22, 2002 IN BOOK 28 OF SURVEYS AT PAGES 103-111 UNDER AUDITOR'S FILE NO. 200211220015, RECORDS OF KITTITAS COUNTY, WASHINGTON; BEING A PORTION OF THE SOUTHWEST QUARTER OF SECTION 17, TOWNSHIP 18 NORTH, RANGE 18 EAST, W.M., IN THE COUNTY OF KITTITAS, STATE OF WASHINGTON.

LEGAL DESCRIPTIONS (CONT.)

PARCEL 13

PARCEL 13 OF THAT CERTAIN SURVEY AS RECORDED NOVEMBER 22, 2002 IN BOOK 28 OF SURVEYS AT PAGES 103-111 UNDER AUDITOR'S FILE NO. 200211220015, RECORDS OF KITTITAS COUNTY, WASHINGTON; BEING A PORTION OF THE SOUTHWEST QUARTER OF SECTION 17, TOWNSHIP 18 NORTH, RANGE 18 EAST, W.M., IN THE COUNTY OF KITTITAS, STATE OF WASHINGTON.

PARCEL 14

PARCEL 14 OF THAT CERTAIN SURVEY AS RECORDED NOVEMBER 22, 2002 IN BOOK 28 OF SURVEYS AT PAGES 103-111 UNDER AUDITOR'S FILE NO. 200211220015, RECORDS OF KITTITAS COUNTY, WASHINGTON; BEING A PORTION OF THE EAST HALF OF SECTION 18, TOWNSHIP 18 NORTH, RANGE 18 EAST, W.M., IN THE COUNTY OF KITTITAS, STATE OF WASHINGTON.

PARCEL 15

PARCEL 15 OF THAT CERTAIN SURVEY AS RECORDED NOVEMBER 22, 2002 IN BOOK 28 OF SURVEYS AT PAGES 103-111 UNDER AUDITOR'S FILE NO. 200211220015, RECORDS OF KITTITAS COUNTY, WASHINGTON; BEING A PORTION OF THE NORTHEAST QUARTER OF SECTION 18, TOWNSHIP 18 NORTH, RANGE 18 EAST, W.M., IN THE COUNTY OF KITTITAS, STATE OF WASHINGTON.

PARCEL 16

PARCEL 16 OF THAT CERTAIN SURVEY AS RECORDED NOVEMBER 22, 2002 IN BOOK 28 OF SURVEYS AT PAGES 103-111 UNDER AUDITOR'S FILE NO. 200211220015, RECORDS OF KITTITAS COUNTY, WASHINGTON; BEING A PORTION OF THE NORTHEAST QUARTER OF SECTION 18, TOWNSHIP 18 NORTH, RANGE 18 EAST, W.M., IN THE COUNTY OF KITTITAS, STATE OF WASHINGTON.

PARCEL 17

PARCEL 17 OF THAT CERTAIN SURVEY AS RECORDED NOVEMBER 22, 2002 IN BOOK 28 OF SURVEYS AT PAGES 103-111 UNDER AUDITOR'S FILE NO. 200211220015, RECORDS OF KITTITAS COUNTY, WASHINGTON; BEING A PORTION OF THE NORTHEAST QUARTER OF SECTION 18, TOWNSHIP 18 NORTH, RANGE 18 EAST, W.M., IN THE COUNTY OF KITTITAS, STATE OF WASHINGTON.

PARCEL 18

PARCEL 18 OF THAT CERTAIN SURVEY AS RECORDED NOVEMBER 22, 2002 IN BOOK 28 OF SURVEYS AT PAGES 103-111 UNDER AUDITOR'S FILE NO. 200211220015, RECORDS OF KITTITAS COUNTY, WASHINGTON; BEING A PORTION OF THE NORTHWEST QUARTER OF SECTION 18, TOWNSHIP 18 NORTH, RANGE 18 EAST, W.M., IN THE COUNTY OF KITTITAS, STATE OF WASHINGTON.

PARCEL 19

PARCEL 19 OF THAT CERTAIN SURVEY AS RECORDED NOVEMBER 22, 2002 IN BOOK 28 OF SURVEYS AT PAGES 103-111 UNDER AUDITOR'S FILE NO. 200211220015, RECORDS OF KITTITAS COUNTY, WASHINGTON; BEING A PORTION OF THE NORTHEAST QUARTER OF SECTION 18, TOWNSHIP 18 NORTH, RANGE 18 EAST, W.M., IN THE COUNTY OF KITTITAS, STATE OF WASHINGTON.

PARCEL 20

PARCEL 20 OF THAT CERTAIN SURVEY AS RECORDED NOVEMBER 22, 2002 IN BOOK 28 OF SURVEYS AT PAGES 103-111 UNDER AUDITOR'S FILE NO. 200211220015, RECORDS OF KITTITAS COUNTY, WASHINGTON; BEING A PORTION OF THE NORTHWEST QUARTER OF SECTION 18, TOWNSHIP 18 NORTH, RANGE 18 EAST, W.M., IN THE COUNTY OF KITTITAS, STATE OF WASHINGTON.

PARCEL 21

PARCEL 21 OF THAT CERTAIN SURVEY AS RECORDED NOVEMBER 22, 2002 IN BOOK 28 OF SURVEYS AT PAGES 103-111 UNDER AUDITOR'S FILE NO. 200211220015, RECORDS OF KITTITAS COUNTY, WASHINGTON; BEING A PORTION OF THE NORTHWEST QUARTER OF SECTION 18, TOWNSHIP 18 NORTH, RANGE 18 EAST, W.M., IN THE COUNTY OF KITTITAS, STATE OF WASHINGTON.

EASEMENT Q

EASEMENT Q AS DELINEATED ON THAT CERTAIN SURVEY RECORDED NOVEMBER 22, 2002 IN BOOK 28 OF SURVEYS AT PAGES UNDER AUDITOR'S FILE NO. 200211220015, RECORDS OF KITTITAS COUNTY, WASHINGTON; BEING ACROSS A PORTION OF THE SOUTHWEST QUARTER OF SECTION 18, TOWNSHIP 18 NORTH, RANGE 18 EAST, W.M., IN THE COUNTY OF KITTITAS, STATE OF WASHINGTON; AFFECTING PARCEL 2 OF SAID SURVEY.

AUDITOR'S CERTIFICATE

Filed for record this 22ND day of NOVEMBER, 2002, at 12:07 p.m., in Book 28 of Surveys at page(s) 103-111 at the request of Cruse & Associates.

DAVID B. BOWEN, Auditor, Kittitas County Auditor

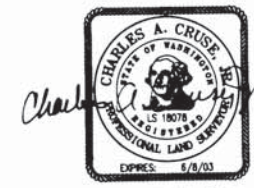

CRUSE & ASSOCIATES PROFESSIONAL LAND SURVEYORS 217 East Fourth Street P.O. Box 959 Ellensburg, WA 98926 (509) 962-8242 McMANAMY PROPERTY